

REVISIONS			
REV.	DESCRIPTION	DATE	APRVD.
D	FOR REFERENCE ONLY	2018-01-23	JSK

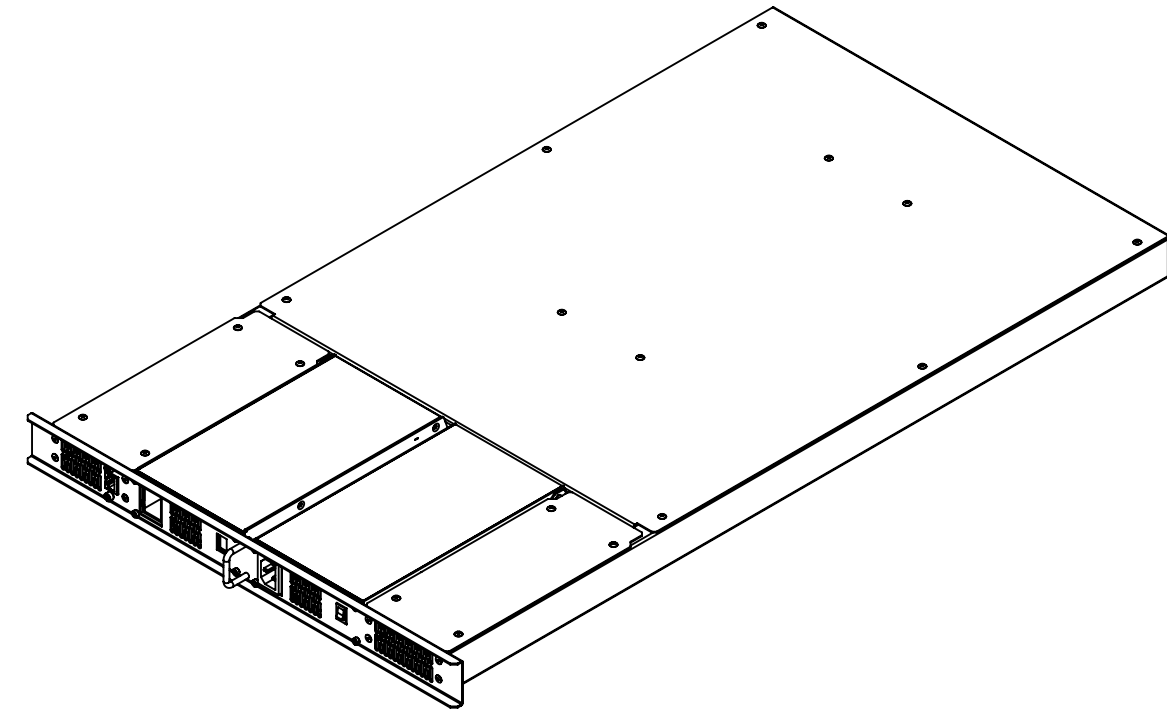

[44.1]
1.74
SHEET METAL
TO RIVET HEAD

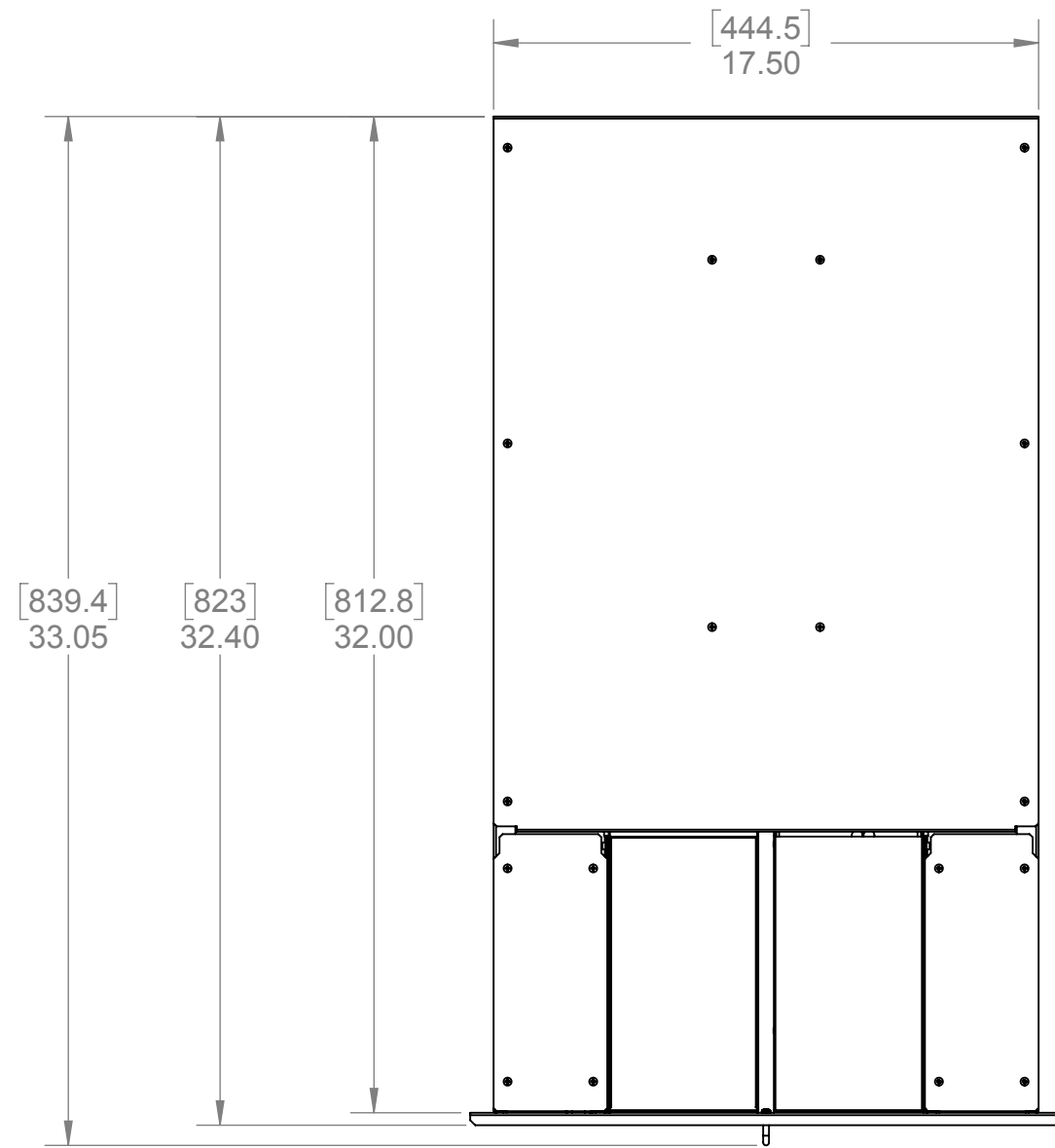
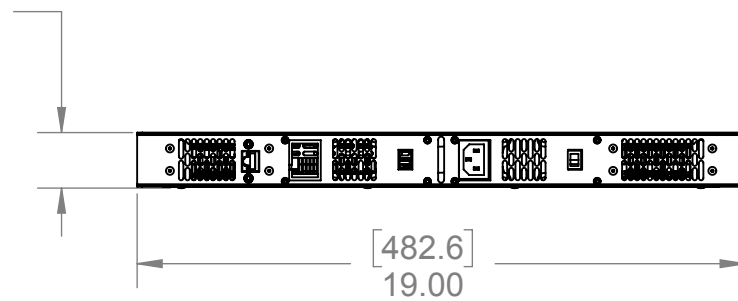

[43]
1.69

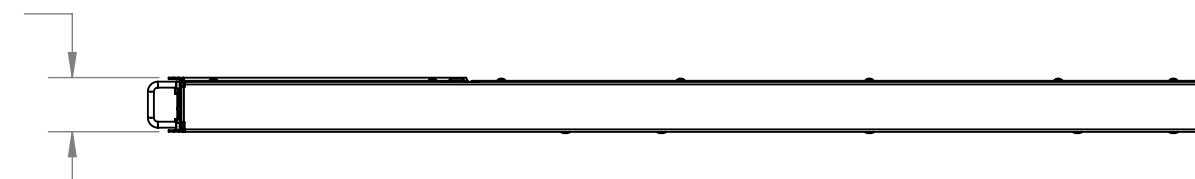

[40.5]
1.60

- NOTES:
- DRAWING IS FOR REFERENCE ONLY
 - ALL DIMENSIONS SHOWN ARE NOMINAL

PROPRIETARY AND CONFIDENTIAL: THE INFORMATION CONTAINED IN THIS DRAWING IS THE SOLE PROPERTY OF OBELISK, INC. ANY REPRODUCTION IN PART OR AS A WHOLE WITHOUT THE WRITTEN PERMISSION OF OBELISK, INC. IS PROHIBITED.			
UNLESS OTHERWISE SPECIFIED: MATERIAL: <small>DIMENSIONS ARE IN INCHES ALL UNTOLERANCED DIMENSIONS ARE BASIC TOLERANCES: FRACTIONAL ±.132" ANGULAR .X ±0.5° LINEAR .XX ±0.03 .XXX ±0.01 .XXX ±0.005</small>		DESCRIPTION: RACK SLED ASSEM, 1U	
FINISH: <small>FINISH √R_a 500 INTERPRET GD&T PER ASME Y14.5M-1994</small>		PART NO: 1735102	
PROCESS: SUPPLIER PART NO:		DRAWN BY: _____ DRAWN DATE: _____ REV. D	
DO NOT SCALE DRAWING		SIZE: B	SCALE: 1:6 SHEET: 1 OF 1